



Surge Control Products



Fluid Energy Control Surge Suppressors

Fluid Energy Controls Surge Stop Surge Suppressors are designed to dampen the pressure surges caused by rapid closing and opening of flow control valves in any liquid handling system. This reduces the possibility of costly damage to the pipelines, leakage loosened pipe fittings and downtime.

FEC Surge Suppressor Benefits:

- Protects pipes, valves, fittings, meters, and in-line instrumentation from destructive pulsations, surges, cavitations, thermal expansion, and water-hammer.
- Creates steady and continuous flow when dosing, blending or proportioning additives.
- Ensures accuracy, longevity, and repeatability of in-line meters.
- Enables uniform application of material in spraying and coating systems.
- Reduces agitation, foaming, splashing and degradation of product.
- Provides liquid energy storage for emergency valve closure and other equipment shutdown.
- Reduces overall energy cost with continuous flow, rather than start/stop flow.
- Operates as a reservoir for make-up fluid.



Bottom Repairable Surge Suppressors

- Shell assembly: Carbon steel, epoxy coated internally
- Other wetted parts: 300 series stainless steel
- Design pressure: 275 PSI
- Bladder material: Buna-N; Other compounds available
- ASME Coded per Section VIII, Div. 1, U-Stamped, National Board Registered

Nominal Size gal.	"A" in. (Aprox.)	"B" Dia. in.	"C" Fluid Port Connection	Est. Dry Wt. lb.	Model Number	
					Surge Suppressors	Repair Kit
2.5	17½	8⅝	3"-150# ANSI Flange	49	7652000	5250102
5	29¼	8⅝	3"-150# ANSI Flange	86	7653000	5250074
10	50	8⅝	3"-150# ANSI Flange	138	7654000	5250087

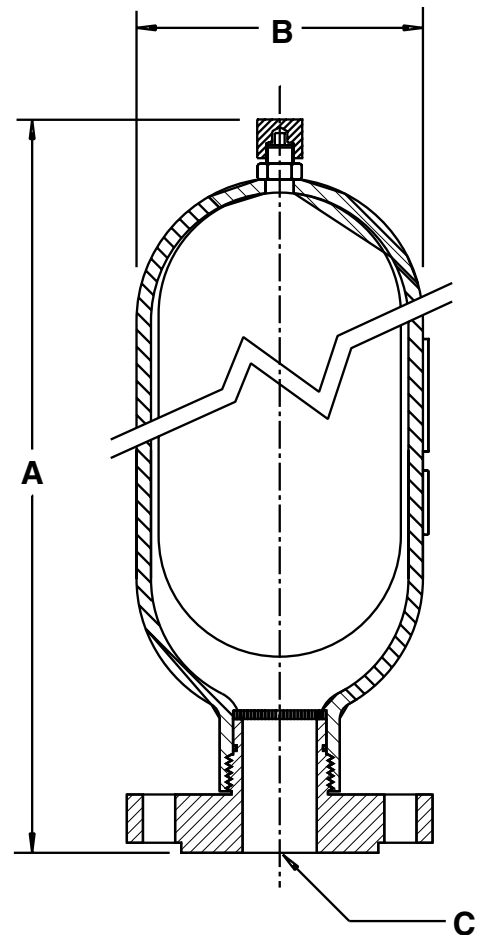

Pre-Charge Monitor Schedule

The Accumulators, Surge Suppressors and Pulsation dampeners shipped from the factory of Fluid Energy Controls are only pre-charged to 20 psi with dry Nitrogen gas. This pre-charge protects the bladders from getting damaged during shipping. After installation of the unit, the bladder inside the unit needs to be properly pre-charged with dry Nitrogen gas to 70-80% of the working pressure of the pipeline. The pre-charging is accomplished before the fluid starts pumping in the pipeline.

For newly installed units, the pre-charge should be monitored every two weeks. There should be no fluid pumping through the pipeline during this process. If the pre-charge has dropped, then more Nitrogen gas should be pumped into the bladder to raise the pre-charge in the bladder to the recommended pressure. When there is no loss of pre-charge noticed, the pre-charge should be monitored every four weeks.

Caution: Do not use Oxygen or air to pre-charge the bladder. Use only Nitrogen for pre-charging.

Top Repairable Surge Suppressors

Fluid Energy Controls Surge Suppressors are designed to dampen the pressure surges caused by rapid opening and closing of flow control valves in any liquid handling system. This reduces the possibility of costly damage to the pipe lines, leakages, loosened pipe fittings and downtime.

Features:

- Designed and stamped per ASME Section VIII Div. 1, N.B. registered
- Other certifications available:
Chinese SELO, European CE, Canadian CRN, Brazilian NR-13, Malaysian DOSH
- 304 Stainless Steel construction standard (316 Stainless Steel construction available)
- 500psi design operating pressure @ -20°F to +185°F.
- Top repairable design for ease of maintenance.
- Buna-N bladder standard; other compounds available: Viton, EPR, Hydrin

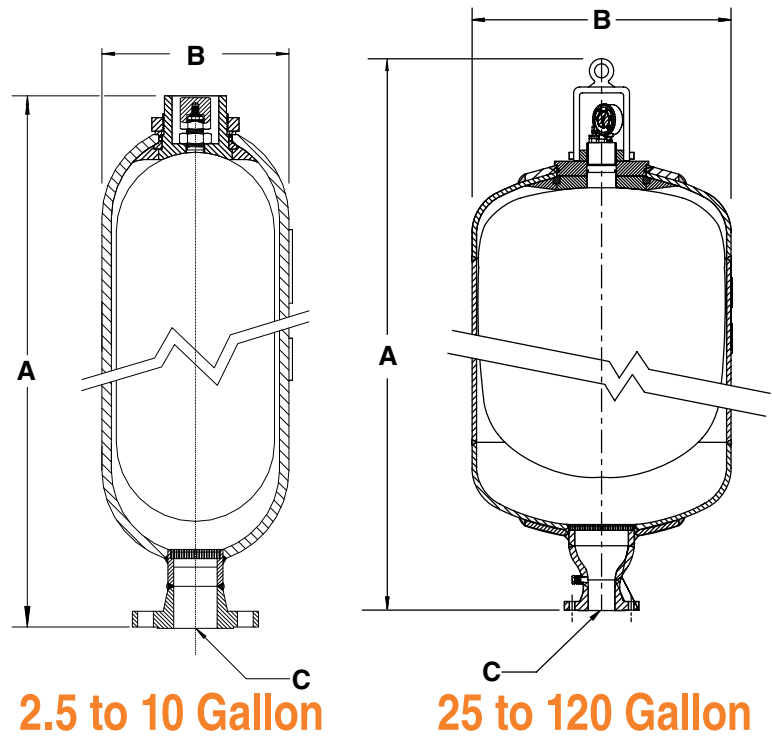

© COPYRIGHT 2009, FLUID ENERGY CONTROLS

Nominal Size	Est. Wt. Dry	"A" Dim. in.	"B" Dim. in.	"C" Fluid Port Conn.	Part Number	
					Surge Suppressor	Repair Kit
2½ Gal.	65 lb.	22	8.65	3" 300# ANSI Flange	7180000	5250020
5 Gal.	95 lb.	32.5	8.65	3" 300# ANSI Flange	7181000	5250024
10 Gal.	150 lb.	54.5	8.65	3" 300# ANSI Flange	7182000	5250006
25 Gal.	315 lb.	36	22	4" 300# ANSI Flange	7183000	5250040
40 Gal.	372 lb.	43.5	22	4" 300# ANSI Flange	7184000	5250029
80 Gal.	655 lb.	65	22	4" 300# ANSI Flange	7185000	5250027
100 Gal.	880 lb.	85	22	4" 300# ANSI Flange	7186000	5250023
120 Gal.	1005 lb.	102	22	4" 300# ANSI Flange	7187000	5250026

Note: All dimensions and weights are for general information only. Since products are in a continual state of refinement, please verify all critical dimensions with Fluid Energy Controls, Inc. Other materials of construction, pressure and connection are available upon request.

Warranty: Fluid Energy Controls, Inc. guarantees its products for materials and workmanship for one full year from the date of purchase, but because we cannot anticipate or control the many different conditions under which this information and our products may be used, we do not guarantee the applicability or suitability

of our products in any given situation. Users of our products should make their own tests to determine the suitability of each product for their particular purpose. The products discussed are sold with a limited warranty and buyer assumes all responsibility for loss or damage arising from the handling and use of our products whether done in accordance with directions or not. Also, statements concerning the possible use of our products are not intended as recommendations to use our products.



FLUID ENERGY CONTROLS, INC.
6431 FLOTILLA STREET
LOS ANGELES, CALIFORNIA 90040
TELEPHONE (323) 721-0588 • FAX (323) 721-8368
E-MAIL: sales@fecintl.com • www.fecintl.com